

## SBS 1.1-COMPLIANT GAS GAUGE ENABLED WITH IMPEDANCE TRACK™ TECHNOLOGY FOR USE WITH THE bq29330

Check for Samples: [bq20z60-R1](#)

### FEATURES

- **Next Generation Patented Impedance Track™ Technology Accurately Measures Available Charge in Li-Ion and Li-Polymer Batteries**
  - Better Than 1% Error Over the Lifetime of the Battery
- **Supports the Smart Battery Specification SBS V1.1**
- **Flexible Configuration for 2-, 3-, and 4-Series Li-Ion and Li-Polymer Cells**
- **Powerful 8-Bit RISC CPU With Ultralow Power Modes**
- **Full Array of Programmable Protection Features**
  - Voltage, Current, and Temperature
- **Satisfies JEITA Guidelines**
- **Added Flexibility to Handle More Complex Charging Profiles**
- **Lifetime Data Logging**
- **Drives 3-, 4-, or 5-Segment LED Display for Battery-Pack Conditions**
- **Supports SHA-1 Authentication**
- **Available in 30-Pin TSSOP (DBT) and 32-Pin QFN (RSM) Packages**

### APPLICATIONS

- **Notebook PCs**
- **Medical and Test Equipment**
- **Portable Instrumentation**

### DESCRIPTION

The bq20z60-R1 SBS-compliant gas gauge and protection IC, incorporating patented Impedance Track™ technology, is designed for battery-pack or in-system installation. The bq20z60-R1 measures and maintains an accurate record of available charge in Li-Ion or Li-Polymer batteries, using its integrated high-performance analog peripherals. The bq20z60-R1 monitors capacity change, battery impedance, open-circuit voltage, and other critical parameters of the battery pack, which reports the information to the system host controller over a serial-communication bus. It is designed to work with the bq29330 analog front-end (AFE) protection IC to maximize functionality and safety, while minimizing external component count and cost in smart battery circuits.

The Impedance Track™ technology continuously analyzes the battery impedance, resulting in superior gas-gauging accuracy. This enables the remaining capacity to be calculated with discharge rate, temperature, and cell aging, which are all accounted for during each stage of every cycle with high accuracy.

**Table 1. AVAILABLE OPTIONS**

T <sub>A</sub>	PACKAGE			
	30-PIN TSSOP (DBT) Tube	30-PIN TSSOP (DBT) Tape & Reel	32-PIN QFN (RSM) Tube	32-PIN QFN (RSM) Tape & Reel
–40°C to 85°C	bq20z60-R1DBT <sup>(1)</sup>	bq20z60-R1DBTR <sup>(2)</sup>	bq20z60-R1RSM <sup>(1)</sup>	bq20z60-R1RSMR <sup>(2)</sup>

(1) A single tube quantity is 60 units.

(2) A single reel quantity is 2000 units.



Please be aware that an important notice concerning availability, standard warranty, and use in critical applications of Texas Instruments semiconductor products and disclaimers thereto appears at the end of this data sheet.

Impedance Track is a trademark of Texas Instruments.

**bq20z60-R1**

SLUS991A – DECEMBER 2009 – REVISED MARCH 2011

www.ti.com

**THERMAL INFORMATION**

THERMAL METRIC <sup>(1)</sup>		bq20z60-R1		UNITS
		TSSOP (DBT)	QFN (RSM)	
		30 PINS	32 PINS	
$\theta_{JA, \text{ High K}}$	Junction-to-ambient thermal resistance <sup>(2)</sup>	81.4	37.4	°C/W
$\theta_{JC(\text{top})}$	Junction-to-case(top) thermal resistance <sup>(3)</sup>	16.2	30.6	
$\theta_{JB}$	Junction-to-board thermal resistance <sup>(4)</sup>	34.1	7.7	
$\psi_{JT}$	Junction-to-top characterization parameter <sup>(5)</sup>	0.4	0.4	
$\psi_{JB}$	Junction-to-board characterization parameter <sup>(6)</sup>	33.6	7.5	
$\theta_{JC(\text{bottom})}$	Junction-to-case(bottom) thermal resistance <sup>(7)</sup>	N/A	2.6	

- (1) For more information about traditional and new thermal metrics, see the *IC Package Thermal Metrics* application report, [SPRA953](#).
- (2) The junction-to-ambient thermal resistance under natural convection is obtained in a simulation on a JEDEC-standard, high-K board, as specified in JESD51-7, in an environment described in JESD51-2a.
- (3) The junction-to-case (top) thermal resistance is obtained by simulating a cold plate test on the package top. No specific JEDEC-standard test exists, but a close description can be found in the ANSI SEMI standard G30-88.
- (4) The junction-to-board thermal resistance is obtained by simulating in an environment with a ring cold plate fixture to control the PCB temperature, as described in JESD51-8.
- (5) The junction-to-top characterization parameter,  $\psi_{JT}$ , estimates the junction temperature of a device in a real system and is extracted from the simulation data for obtaining  $\theta_{JA}$ , using a procedure described in JESD51-2a (sections 6 and 7).
- (6) The junction-to-board characterization parameter,  $\psi_{JB}$ , estimates the junction temperature of a device in a real system and is extracted from the simulation data for obtaining  $\theta_{JA}$ , using a procedure described in JESD51-2a (sections 6 and 7).
- (7) The junction-to-case (bottom) thermal resistance is obtained by simulating a cold plate test on the exposed (power) pad. No specific JEDEC standard test exists, but a close description can be found in the ANSI SEMI standard G30-88.



This integrated circuit can be damaged by ESD. Texas Instruments recommends that all integrated circuits be handled with appropriate precautions. Failure to observe proper handling and installation procedures can cause damage.

ESD damage can range from subtle performance degradation to complete device failure. Precision integrated circuits may be more susceptible to damage because very small parametric changes could cause the device not to meet its published specifications.

**SYSTEM PARTITIONING DIAGRAM**

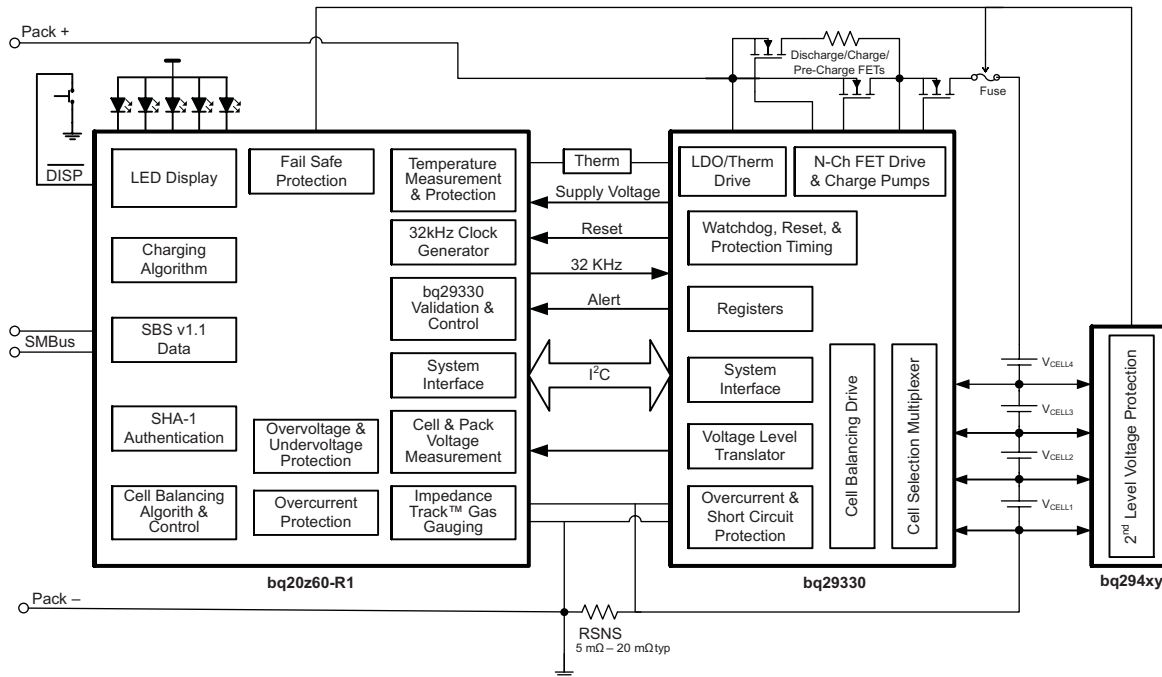

**TSSOP (DBT) PIN FUNCTIONS**

TSSOP (DBT)  
(TOP VIEW)

NC	1	30	VCELL-
XALERT	2	29	VCELL+
SDATA	3	28	NC
SCLK	4	27	RBI
CLKOUT	5	26	VCC
TS1	6	25	VSS
TS2	7	24	MRST
PRES	8	23	SRN
PFIN	9	22	SRP
SAFE	10	21	VSS
SMBD	11	20	LED5
NC	12	19	LED4
SMBC	13	18	LED3
DISP	14	17	LED2
NC	15	16	LED1

**Table 2. TSSOP (DBT) PIN CONFIGURATIONS**

PIN		I/O <sup>(1)</sup>	DESCRIPTION
NO.	NAME		
1	NC	—	Not used—leave floating
2	XALERT	I	Input from bq29330 XALERT output
3	SDATA	I/O	Data transfer to and from bq29330
4	SCLK	I/O	Communication clock to the bq29330
5	CLKOUT	O	32.768-kHz output for the bq29330. This pin should be directly connected to the AFE.
6	TS1	I	1 <sup>st</sup> Thermistor voltage input connection to monitor temperature
7	TS2	I	2 <sup>nd</sup> Thermistor voltage input connection to monitor temperature
8	$\overline{\text{PRES}}$	I	Active low input to sense system insertion. This typically requires additional ESD protection.
9	$\overline{\text{PFIN}}$	I	Active low input to detect secondary protector output status, and to allow the bq20z60-R1 to report the status of the 2 <sup>nd</sup> level protection output
10	SAFE	OD	Active high output to enforce additional level of safety protection; for example, fuse blow
11	SMBD	I/OD	SMBus data open-drain bidirectional pin used to transfer address and data to and from the bq20z60-R1
12	NC	—	Not used—leave floating
13	SMBC	I/OD	SMBus clock open-drain bidirectional pin used to clock the data transfer to and from the bq20z60-R1
14	$\overline{\text{DISP}}$	I	Display control for the LEDs. This pin is typically connected to bq29330 REG via a 100-K $\Omega$ resistor and a push-button switch connect to VSS.
15	NC	—	Not used—leave floating
16	LED1	O	LED1 display segment that drives an external LED depending on the firmware configuration
17	LED2	O	LED2 display segment that drives an external LED depending on the firmware configuration
18	LED3	O	LED3 display segment that drives an external LED depending on the firmware configuration
19	LED4	O	LED4 display segment that drives an external LED depending on the firmware configuration
20	LED5	O	LED5 display segment that drives an external LED depending on the firmware configuration
21	VSS	—	Negative supply voltage
22	SRP	IA	Connections for a small-value sense resistor to monitor the battery charge- and discharge-current flow
23	SRN	IA	Connections for a small-value sense resistor to monitor the battery charge- and discharge-current flow
24	$\overline{\text{MRST}}$	I	Master reset input that forces the device into reset when held low. This pin must be held high for normal operation.
25	VSS	P	Negative supply voltage
26	VCC	P	Positive supply voltage
27	RBI	P	RAM backup input. Connect a capacitor to this pin and VSS to protect loss of RAM data in case of short circuit condition.
28	NC	—	Not used—leave floating
29	VCELL+	I	Input from bq29330 used to read a scaled value of individual cell voltages
30	VCELL-	I	Input from bq29330 used to read a scaled value of individual cell voltages

(1) I = Input, IA = Analog input, I/O = Input/output, I/OD = Input/Open-drain output, O = Output, OA = Analog output, P = Power

### QFN (RSM) PIN FUNCTIONS

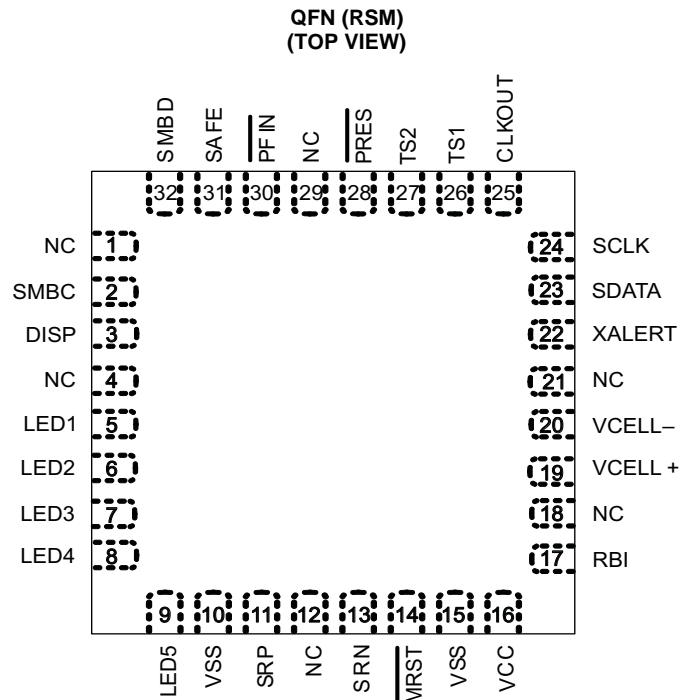

### QFN (RSM) PIN CONFIGURATIONS

PIN		I/O <sup>(1)</sup>	DESCRIPTION
NO.	NAME		
1	NC	—	Not used—leave floating
2	SMBC	I/OD	SMBus clock open-drain bidirectional pin used to clock the data transfer to and from the bq20z60-R1
3	DISP	—	Not used—leave floating
4	NC	—	Not used—leave floating
5	LED1	O	LED1 display segment that drives an external LED depending on the firmware configuration
6	LED2	O	LED2 display segment that drives an external LED depending on the firmware configuration
7	LED3	O	LED3 display segment that drives an external LED depending on the firmware configuration
8	LED4	O	LED4 display segment that drives an external LED depending on the firmware configuration
9	LED5	O	LED5 display segment that drives an external LED depending on the firmware configuration
10	VSS	P	Negative Supply Voltage
11	SRP	IA	Connections for a small-value sense resistor to monitor the battery charge- and discharge-current flow
12	NC	—	Not used—leave floating
13	SRN	IA	Connections for a small-value sense resistor to monitor the battery charge- and discharge-current flow
14	$\overline{\text{MRST}}$	I	Master reset input that forces the device into reset when held low. This pin must be held high for normal operation.
15	VSS	P	Negative Supply Voltage
16	VCC	P	Positive Supply Voltage
17	RBI	P	RAM backup input. Connect a capacitor to this pin and VSS to protect loss of RAM data in case of short circuit condition.
18	NC	—	Not used—leave floating
19	VCELL+	I	Input from bq29330 used to read a scaled value of individual cell voltages
20	VCELL-	I	Input from bq29330 used to read a scaled value of individual cell voltages

(1) I = Input, IA = Analog input, I/O = Input/output, I/OD = Input/Open-drain output, O = Output, OA = Analog output, P = Power

**bq20z60-R1**

SLUS991A – DECEMBER 2009 – REVISED MARCH 2011

[www.ti.com](http://www.ti.com)**QFN (RSM) PIN CONFIGURATIONS (continued)**

PIN		I/O <sup>(1)</sup>	DESCRIPTION
NO.	NAME		
21	NC	—	Not used—leave floating
22	XALERT	I	Input from bq29330 XALERT output
23	SDATA	I/O	Data transfer to and from bq29330
24	SCLK	I/O	Communication clock to the bq29330
25	CLKOUT	O	32.768-kHz output to the bq29330. This pin should be directly connected to the bq29330 AFE.
26	TS1	I	Thermistor 1 input
27	TS2	I	Thermistor 2 input
28	PRES	I	Active low input to sense system insertion. This typically requires additional ESD protection.
29	NC	—	Not used—leave floating
30	PFIN	I	Active low input to detect secondary protector output status, and to allow the bq20z60-R1 to report the status of the 2 <sup>nd</sup> level protection output
31	SAFE	O	Active high output to enforce additional level of safety protection; for example, fuse blow
32	SMBD	I/OD	SMBus data open-drain bidirectional pin used to transfer address and data to and from the bq20z60-R1

**ABSOLUTE MAXIMUM RATINGS**Over operating free-air temperature range (unless otherwise noted)<sup>(1)</sup>

		RANGE
V <sub>CC</sub> relative to V <sub>SS</sub>	Supply voltage range	–0.3 V to 2.75 V
V <sub>(I/O)</sub> relative to V <sub>SS</sub>	Open-drain I/O pins	–0.3 V to 6 V
V <sub>I</sub> relative to V <sub>SS</sub>	Input voltage range to all other pins	–0.3 V to V <sub>CC</sub> + 0.3 V
T <sub>A</sub>	Operating free-air temperature range	–40°C to 85°C
T <sub>stg</sub>	Storage temperature range	–65°C to 150°C

(1) Stresses beyond those listed under absolute maximum ratings may cause permanent damage to the device. These are stress ratings only, and functional operation of the device at these or any other conditions beyond those indicated under recommended operating conditions is not implied. Exposure to absolute-maximum-rated conditions for extended periods may affect device reliability.

**ELECTRICAL CHARACTERISTICS**V<sub>CC</sub> = 2.4 V to 2.6 V, T<sub>A</sub> = –40°C to 85°C (unless otherwise noted)

PARAMETER		TEST CONDITIONS	MIN	TYP	MAX	UNIT
V <sub>CC</sub>	Supply voltage		2.4	2.5	2.6	V
I <sub>CC</sub>	Operating mode current	No flash programming		400 <sup>(1)</sup>		μA
		bq20z60-R1 + bq29330		475		
I <sub>(SLEEP)</sub>	Low-power storage mode current	Sleep mode		8 <sup>(1)</sup>		μA
		bq20z60-R1 + bq29330		51		
I <sub>(SHUTDOWN)</sub>	Low-power shutdown mode current	Shutdown mode		0.1	1	μA
		bq20z60-R1 + bq29330		0.2		
V <sub>OL</sub>	Output voltage low SMBC, SMBD, SDATA, SCLK, SAFE	I <sub>OL</sub> = 0.5 mA			0.4	V
	Output voltage low LED1, LED2, LED3, LED4, LED5	I <sub>OL</sub> = 10 mA			0.4	V
V <sub>OH</sub>	Output voltage high SMBC, SMBD, SDATA, SCLK, SAFE	I <sub>OH</sub> = –1 mA	V <sub>CC</sub> – 0.5			V
V <sub>IL</sub>	Input voltage low SMBC, SMBD, SDATA, SCLK, XALERT, PRES, PFIN, DISP		–0.3		0.8	V

(1) This value does not include the bq29330

## ELECTRICAL CHARACTERISTICS (continued)

 $V_{CC} = 2.4\text{ V to }2.6\text{ V}$ ,  $T_A = -40^\circ\text{C to }85^\circ\text{C}$  (unless otherwise noted)

PARAMETER		TEST CONDITIONS	MIN	TYP	MAX	UNIT
$V_{IH}$	Input voltage high SMBC, SMBD, SDATA, SCLK, XALERT, PRES, PFIN		2		6	V
	Input voltage high $\overline{DISP}$		2		$V_{CC} + 0.3$	V
$C_{IN}$	Input capacitance			5		pF
$V_{(AI1)}$	Input voltage range VCELL+, VCELL-, TS1, TS2		-0.2		$0.8 \times V_{CC}$	V
$V_{(AI2)}$	Input voltage range SRN, SRP		-0.20		0.20	
$Z_{(AI2)}$	Input impedance VCELL+, VCELL-, TS1, TS2	0 V–1 V	8			M $\Omega$
$Z_{(AI1)}$	Input impedance SRN, SRP	0 V–1 V	2.5			M $\Omega$

## POWER-ON RESET

 $V_{CC} = 2.4\text{ V to }2.6\text{ V}$ ,  $T_A = -40^\circ\text{C to }85^\circ\text{C}$  (unless otherwise noted)

PARAMETER		TEST CONDITIONS	MIN	TYP	MAX	UNIT
$V_{IT-}$	Negative-going voltage input		1.7	1.8	1.9	V
$V_{HYS}$	Power-on reset hysteresis		50	125	200	mV

**POWER ON RESET BEHAVIOR  
VS  
FREE-AIR TEMPERATURE**

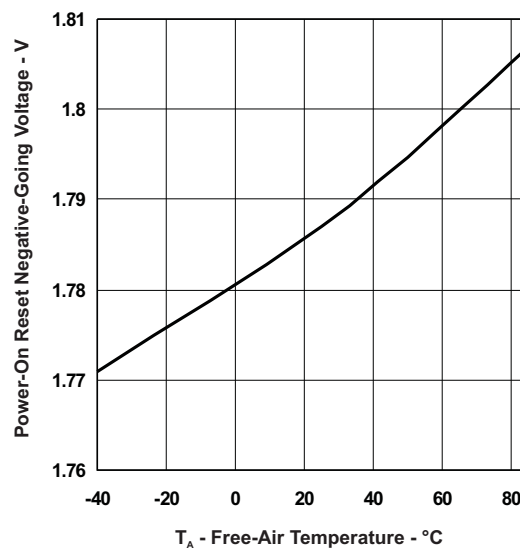

## INTEGRATING ADC (Coulomb Counter) CHARACTERISTICS

 $V_{CC} = 2.4\text{ V to }2.6\text{ V}$ ,  $T_A = -40^\circ\text{C to }85^\circ\text{C}$  (unless otherwise noted)

PARAMETER		TEST CONDITIONS	MIN	TYP	MAX	UNIT
$V_{(SR)}$	Input voltage range, $V_{(SRN)}$ and $V_{(SRP)}$	$V_{(SR)} = V_{(SRN)} - V_{(SRP)}$	-0.2		0.2	V
$V_{(SROS)}$	Input offset			10		$\mu\text{V}$
INL	Integral nonlinearity error			0.007	0.034	%

## OSCILLATOR

 $V_{CC} = 2.4\text{ V to }2.6\text{ V}$ ,  $T_A = -40^\circ\text{C to }85^\circ\text{C}$  (unless otherwise noted)

PARAMETER		TEST CONDITIONS	MIN	TYP	MAX	UNIT
<b>HIGH FREQUENCY OSCILLATOR</b>						

**bq20z60-R1**

SLUS991A – DECEMBER 2009 – REVISED MARCH 2011

[www.ti.com](http://www.ti.com)**OSCILLATOR (continued)** $V_{CC} = 2.4\text{ V to } 2.6\text{ V}$ ,  $T_A = -40^\circ\text{C to } 85^\circ\text{C}$  (unless otherwise noted)

PARAMETER		TEST CONDITIONS	MIN	TYP	MAX	UNIT
$f_{(OSC)}$	Operating frequency				4.194	MHz
$f_{(EIO)}$	Frequency error <sup>(1) (2)</sup>		-3	0.25	3	%
		$T_A = 20^\circ\text{C to } 70^\circ\text{C}$	-2	0.25	2	
$t_{(SXO)}$	Start-up time <sup>(3)</sup>			2.5	5	ms
<b>LOW FREQUENCY OSCILLATOR</b>						
$f_{(LOSC)}$	Operating frequency		32.768			kHz
$f_{(LEIO)}$	Frequency error <sup>(2) (4)</sup>		-2.5	0.25	2.5	%
		$T_A = 20^\circ\text{C to } 70^\circ\text{C}$	-1.5	0.25	1.5	
$t_{(LSXO)}$	Start-up time <sup>(5)</sup>				500	$\mu\text{s}$

(1) The frequency error is measured from 4.194 MHz.

(2) The frequency drift is included and measured from the trimmed frequency at  $V_{CC} = 2.5\text{ V}$ ,  $T_A = 25^\circ\text{C}$ .

(3) The start-up time is defined as the time it takes for the oscillator output frequency to be within 1 % of the specified frequency.

(4) The frequency error is measured from 32.768 kHz.

(5) The start-up time is defined as the time it takes for the oscillator output frequency to be  $\pm 3\%$ .**DATA FLASH MEMORY CHARACTERISTICS** $V_{CC} = 2.4\text{ V to } 2.6\text{ V}$ ,  $T_A = -40^\circ\text{C to } 85^\circ\text{C}$  (unless otherwise noted)

PARAMETER		TEST CONDITIONS	MIN	TYP	MAX	UNIT
$t_{DR}$	Data retention	See <sup>(1)</sup>	10			Years
	Flash programming write-cycles	See <sup>(1)</sup>	20,000			Cycles
$t_{(WORDPROG)}$	Word programming time	See <sup>(1)</sup>			2	ms
$I_{(DDdPROG)}$	Flash-write supply current	See <sup>(1)</sup>		5	10	mA

(1) Specified by design. Not production tested.

**REGISTER BACKUP** $V_{CC} = 2.4\text{ V to } 2.6\text{ V}$ ,  $T_A = -40^\circ\text{C to } 85^\circ\text{C}$  (unless otherwise noted)

PARAMETER		TEST CONDITIONS	MIN	TYP	MAX	UNIT
$I_{(RB)}$	RB data-retention input current	$V_{(RB)} > V_{(RBMIN)}$ , $V_{CC} < V_{IT-}$			1500	nA
		$V_{(RB)} > V_{(RBMIN)}$ , $V_{CC} < V_{IT-}$ , $T_A = 0^\circ\text{C to } 50^\circ\text{C}$		40	160	
$V_{(RB)}$	RB data-retention voltage <sup>(1)</sup>		1.7			V

(1) Specified by design. Not production tested.

**SMBus TIMING SPECIFICATIONS** $V_{CC} = 2.4\text{ V to } 2.6\text{ V}$ ,  $T_A = -40^\circ\text{C to } 85^\circ\text{C}$  (unless otherwise noted)

PARAMETER		TEST CONDITIONS	MIN	TYP	MAX	UNIT
$f_{SMB}$	SMBus operating frequency	Slave mode, SMBC 50% duty cycle	10		100	kHz
$f_{MAS}$	SMBus master clock frequency	Master mode, no clock low slave extend		51.2		
$t_{BUF}$	Bus free time between start and stop		4.7			$\mu\text{s}$
$t_{HD:STA}$	Hold time after (repeated) start		4			
$t_{SU:STA}$	Repeated start setup time		4.7			
$t_{SU:STO}$	Stop setup time		4			
$t_{HD:DAT}$	Data hold time	Receive mode	0			ns
		Transmit mode	300			
$t_{SU:DAT}$	Data setup time		250			
$t_{TIMEOUT}$	Error signal/detect	See <sup>(1)</sup>	25		35	ms

(1) The bq20z60-R1 times out when any clock low exceeds  $t_{TIMEOUT}$ .

**SMBus TIMING SPECIFICATIONS (continued)**

V<sub>CC</sub> = 2.4 V to 2.6 V, T<sub>A</sub> = -40°C to 85°C (unless otherwise noted)

PARAMETER		TEST CONDITIONS	MIN	TYP	MAX	UNIT
t <sub>LOW</sub>	Clock low period		4.7			μs
t <sub>HIGH</sub>	Clock high period	See (2)	4		50	
t <sub>LOW:SEXT</sub>	Cumulative clock low slave extend time	See (3)			25	ms
t <sub>LOW:MEXT</sub>	Cumulative clock low master extend time	See (4)			10	
t <sub>F</sub>	Clock/data fall time	(V <sub>ILMAX</sub> - 0.15 V) to (V <sub>IHMIN</sub> + 0.15 V)			300	ns
t <sub>R</sub>	Clock/data rise time	0.9 V <sub>CC</sub> to (V <sub>ILMAX</sub> - 0.15 V)			1000	

- (2) t<sub>HIGH:MAX</sub> is minimum bus idle time. SMBC = 1 for t > 50 μs causes reset of any transaction involving the bq20z60-R1 that is in progress.
- (3) t<sub>LOW:SEXT</sub> is the cumulative time a slave device is allowed to extend the clock cycles in one message from initial start to the stop.
- (4) t<sub>LOW:MEXT</sub> is the cumulative time a master device is allowed to extend the clock cycles in one message from initial start to the stop.

**SMBus TIMING DIAGRAM**

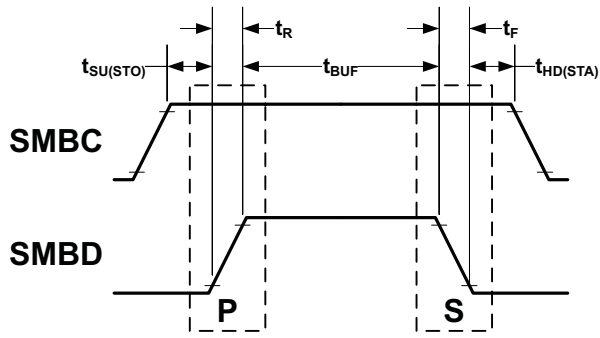

Start and Stop condition

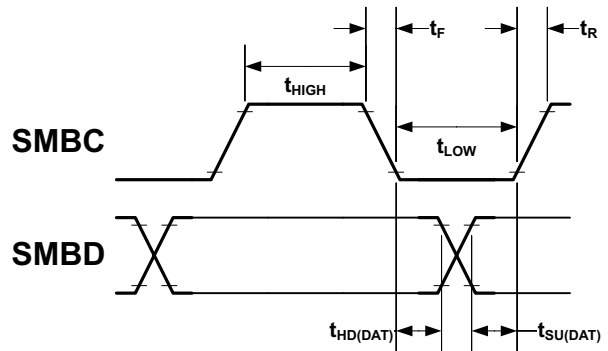

Wait and Hold condition

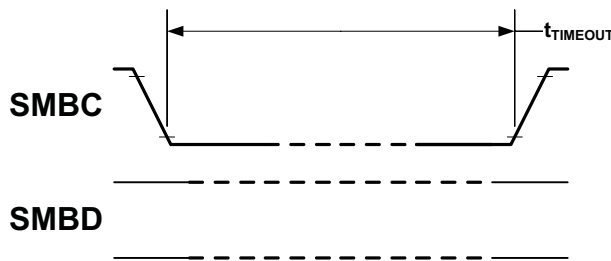

Timeout condition

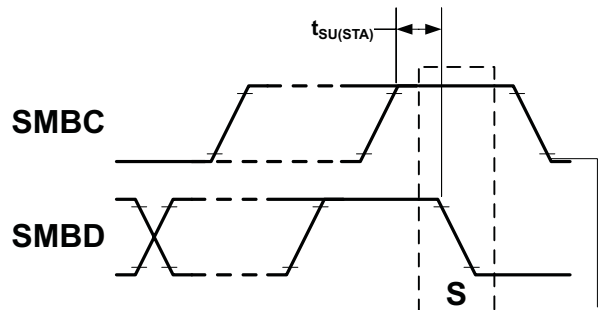

Repeated Start condition

A. SCLKACK is the acknowledge related clock pulse generated by the master.

## FEATURE SET

### Primary (1st Level) Safety Features

The bq20z60-R1 supports a wide range of battery and system protection features that can easily be configured. The primary safety features include:

- Cell over/undervoltage protection
- Charge and discharge overcurrent
- Short circuit protection
- Charge and discharge overtemperature with independent alarms and thresholds for each thermistor
- AFE Watchdog

### Secondary (2nd Level) Safety Features

The secondary safety features of the bq20z60-R1 can be used to indicate more serious faults via the SAFE pin. This pin can be used to blow an in-line fuse to permanently disable the battery pack from charging or discharging. The secondary safety protection features include:

- Safety overvoltage
- Safety undervoltage
- 2nd level protection IC input
- Safety over current in charge and discharge
- Safety overtemperature in charge and discharge with independent alarms and thresholds for each thermistor
- Charge FET and zero-volt Charge FET fault
- Discharge FET fault
- Cell imbalance detection (active and at rest)
- Open thermistor detection
- AFE communication fault

### Charge Control Features

The bq20z60-R1 charge control features include:

- Supports JEITA temperature ranges. Reports charging voltage and charging current according to the active temperature range
- Handles more complex charging profiles. Allows for splitting the standard temperature range into two sub-ranges and allows for varying the charging current according to the cell voltage.
- Reports the appropriate charging current needed for constant current charging and the appropriate charging voltage needed for constant voltage charging to a smart charger using SMBus broadcasts
- Determines the chemical state of charge of each battery cell using Impedance Track, and reduces the charge difference of the battery cells in fully charged state of the battery pack, gradually using the cell balancing algorithm during charging. This prevents fully charged cells from overcharging and causing excessive degradation, and also increases the usable pack energy by preventing premature charge termination.
- Supports pre-charging/zero-volt charging
- Supports charge inhibit and charge suspend if battery pack temperature is out of temperature range
- Reports charging fault and also indicate charge status via charge and discharge alarms

### Gas Gauging

The bq20z60-R1 uses the Impedance Track technology to measure and calculate the available charge in battery cells. The achievable accuracy is better than 1% error over the lifetime of the battery and there is no full charge discharge learning cycle required.

See *Theory and Implementation of Impedance Track Battery Fuel-Gauging Algorithm* application note ([SLUA364](#)) for further details.

## Lifetime Data Logging Features

The bq20z60-R1 offers lifetime data logging, where important measurements are stored for warranty and analysis purposes. The data monitored includes:

- Lifetime maximum temperature
- Lifetime maximum temperature count
- Lifetime maximum temperature duration
- Lifetime minimum temperature
- Lifetime maximum battery cell voltage
- Lifetime maximum battery cell voltage count
- Lifetime maximum battery cell voltage duration
- Lifetime minimum battery cell voltage
- Lifetime maximum battery pack voltage
- Lifetime minimum battery pack voltage
- Lifetime maximum charge current
- Lifetime maximum discharge current
- Lifetime maximum charge power
- Lifetime maximum discharge power
- Lifetime maximum average discharge current
- Lifetime maximum average discharge power
- Lifetime average temperature

## Authentication

The bq20z60-R1 supports authentication by the host using SHA-1.

## Power Modes

The bq20z60-R1 supports three separate power modes to reduce power consumption:

- In Normal Mode, the bq20z60-R1 performs measurements, calculations, protection decisions, and data updates in 1-s intervals. Between these intervals, the bq20z60-R1 is in a reduced power stage.
- In Sleep Mode, the bq20z60-R1 performs measurements, calculations, protection decisions, and data updates in adjustable time intervals. Between these intervals, the bq20z60-R1 is in a reduced power stage. The bq20z60-R1 has a wake function that enables exit from Sleep mode when current flow or failure is detected.
- In Shutdown Mode, the bq20z60-R1 is completely disabled.

## CONFIGURATION

### Oscillator Function

The bq20z60-R1 fully integrates the system oscillators; therefore, no external components are required for this feature.

### System Present Operation

The bq20z60-R1 periodically verifies the  $\overline{\text{PRES}}$  pin and detects that the battery is present in the system via a low state on a  $\overline{\text{PRES}}$  input. When this occurs, the bq20z60-R1 enters normal operating mode. When the pack is removed from the system and the  $\overline{\text{PRES}}$  input is high, the bq20z60-R1 enters the battery-removed state, disabling the charge, discharge, and ZVCHG FETs. The  $\overline{\text{PRES}}$  input is ignored and can be left floating when non-removal mode is set in the data flash.

## bq20z60-R1

SLUS991A – DECEMBER 2009 – REVISED MARCH 2011

www.ti.com

### BATTERY PARAMETER MEASUREMENTS

The bq20z60-R1 uses an integrating delta-sigma analog-to-digital converter (ADC) for current measurement, and a second delta-sigma ADC for individual cell and battery voltage and temperature measurement.

#### Charge and Discharge Counting

The integrating delta-sigma ADC measures the charge/discharge flow of the battery by measuring the voltage drop across a small-value sense resistor between the SRP and SRN pins. The integrating ADC measures bipolar signals from  $-0.25\text{ V}$  to  $0.25\text{ V}$ . The bq20z60-R1 detects charge activity when  $V_{SR} = V_{(SRP)} - V_{(SRN)}$  is positive and discharge activity when  $V_{SR} = V_{(SRP)} - V_{(SRN)}$  is negative. The bq20z60-R1 continuously integrates the signal over time, using an internal counter. The fundamental rate of the counter is  $0.65\text{ nVh}$ .

#### Voltage

The bq20z60-R1 updates the individual series cell voltages through the bq29330 at 1-s intervals. The bq20z60-R1 configures the bq29330 to connect the selected cell, cell offset, or bq29330 VREF to the CELL pin of the bq29330, which is required to be connected to VIN of the bq20z60-R1. The internal ADC of the bq20z60-R1 measures the voltage, scales it, and calibrates itself appropriately. This data is also used to calculate the impedance of the cell for the Impedance Track gas-gauging.

#### Current

The bq20z60-R1 uses the SRP and SRN inputs to measure and calculate the battery charge and discharge current using a  $5\text{-m}\Omega$  to  $20\text{-m}\Omega$  typ. sense resistor.

#### Wake Function

The bq20z60-R1 can exit sleep mode, if enabled, by the presence of a programmable level of current signal across SRP and SRN.

#### Auto Calibration

The bq20z60-R1 provides an auto-calibration feature to cancel the voltage offset error across SRP and SRN for maximum charge measurement accuracy. The bq20z60-R1 performs auto-calibration when the SMBus lines stay low continuously for a minimum of a programmable amount of time.

#### Temperature

The bq20z60-R1 has an internal temperature sensor and inputs for two external temperature sensors, TS1 and TS2, used in conjunction with two identical NTC thermistors (default are Semitec 103AT) to sense the battery environmental temperature. The bq20z60-R1 can be configured to use the internal temperature sensor, or up to two external temperature sensors.

### COMMUNICATIONS

The bq20z60-R1 uses SMBus v1.1 with Master Mode and package error checking (PEC) options per the SBS specification.

#### SMBus On and Off State

The bq20z60-R1 detects an SMBus off state when SMBC and SMBD are logic-low for  $\geq 2$  seconds. Clearing this state requires either SMBC or SMBD to transition high. Within 1 ms, the communication bus is available.

## SBS Commands

**Table 3. SBS COMMANDS**

SBS CMD	MODE	NAME	FORMAT	SIZE IN BYTES	MIN VALUE	MAX VALUE	DEFAULT VALUE	UNIT
0x00	R/W	ManufacturerAccess	Hex	2	0x0000	0xffff	—	—
0x01	R/W	RemainingCapacityAlarm	Integer	2	0	700 or 1000	300 or 432	mAh or 10 mWh
0x02	R/W	RemainingTimeAlarm	Unsigned Integer	2	0	30	10	min
0x03	R/W	BatteryMode	Hex	2	0x0000	0xffff	—	—
0x04	R/W	AtRate	Integer	2	–32,768	32,767	0	mA or 10 mW
0x05	R	AtRateTimeToFull	Unsigned Integer	2	0	65,535	—	min
0x06	R	AtRateTimeToEmpty	Unsigned Integer	2	0	65,535	—	min
0x07	R	AtRateOK	Unsigned Integer	2	0	65,535	—	—
0x08	R	Temperature	Unsigned Integer	2	0	65,535	—	0.1°K
0x09	R	Voltage	Unsigned Integer	2	0	20,000	—	mV
0x0a	R	Current	Integer	2	–32,768	32,767	—	mA
0x0b	R	AverageCurrent	Integer	2	–32,768	32,767	—	mA
0x0c	R	MaxError	Unsigned Integer	1	0	100	—	%
0x0d	R	RelativeStateOfCharge	Unsigned Integer	1	0	100	—	%
0x0e	R	AbsoluteStateOfCharge	Unsigned Integer	1	0	100+	—	%
0x0f	R/W	RemainingCapacity	Unsigned Integer	2	0	65,535	—	mAh or 10 mWh
0x10	R	FullChargeCapacity	Unsigned Integer	2	0	65,535	—	mAh or 10 mWh
0x11	R	RunTimeToEmpty	Unsigned Integer	2	0	65,534	—	min
0x12	R	AverageTimeToEmpty	Unsigned Integer	2	0	65,534	—	min
0x13	R	AverageTimeToFull	Unsigned Integer	2	0	65,534	—	min
0x14	R	ChargingCurrent	Unsigned Integer	2	0	65,534	—	mA
0x15	R	ChargingVoltage	Unsigned Integer	2	0	65,534	—	mV
0x16	R	BatteryStatus	Hex	2	0x0000	0xdbff	—	—
0x17	R/W	CycleCount	Unsigned Integer	2	0	65,535	0	—
0x18	R/W	DesignCapacity	Integer	2	0	32,767	4400 or 6336	mAh or 10 mWh
0x19	R/W	DesignVoltage	Integer	2	7000	18,000	14,400	mV
0x1a	R/W	SpecificationInfo	Hex	2	0x0000	0xffff	0x0031	—
0x1b	R/W	ManufactureDate	Unsigned Integer	2	—	65,535	0	—
0x1c	R/W	SerialNumber	Hex	2	0x0000	0xffff	0	—
0x20	R/W	ManufacturerName	String	11+1	—	—	Texas Instruments	—
0x21	R/W	DeviceName	String	7+1	—	—	bq20z60-R1	—
0x22	R/W	DeviceChemistry	String	4+1	—	—	LION	—
0x23	R/W	ManufacturerData	String	14+1	—	—	—	—
0x2f	R/W	Authenticate	String	20+1	—	—	—	—
0x3c	R	CellVoltage4	Unsigned Integer	2	0	65,535	—	mV
0x3d	R	CellVoltage3	Unsigned Integer	2	0	65,535	—	mV
0x3e	R	CellVoltage2	Unsigned Integer	2	0	65,535	—	mV
0x3f	R	CellVoltage1	Unsigned Integer	2	0	65,535	—	mV

Table 4. EXTENDED SBS COMMANDS

SBS CMD	MODE	NAME	FORMAT	SIZE IN BYTES	MIN VALUE	MAX VALUE	DEFAULT VALUE	UNIT
0x45	R	AFEData	String	11+1	—	—	—	—
0x46	R/W	FETControl	Hex	2	0x00	0xff	—	—
0x4f	R	StateOfHealth	Hex	2	0x0000	0xffff	—	—
0x50	R	SafetyAlert	Hex	2	0x0000	0xffff	—	—
0x51	R	SafetyStatus	Hex	2	0x0000	0xffff	—	—
0x52	R	PFAAlert	Hex	2	0x0000	0xffff	—	—
0x53	R	PFStatus	Hex	2	0x0000	0xffff	—	—
0x54	R	OperationStatus	Hex	2	0x0000	0xffff	—	—
0x55	R	ChargingStatus	Hex	2	0x0000	0xffff	—	—
0x57	R	ResetData	Hex	2	0x0000	0xffff	—	—
0x58	R	WDRResetData	Unsigned Integer	2	0	65,535	—	—
0x5a	R	PackVoltage	Unsigned Integer	2	0	65,535	—	mV
0x5d	R	AverageVoltage	Unsigned Integer	2	0	65,535	—	mV
0x5e	R	TS1Temperature	Integer	2	–400	1200	—	0.1°C
0x5f	R	TS2Temperature	Integer	2	–400	1200	—	0.1°C
0x60	R/W	UnSealKey	Hex	4	0x00000000	0xffffffff	—	—
0x61	R/W	FullAccessKey	Hex	4	0x00000000	0xffffffff	—	—
0x62	R/W	PFKey	Hex	4	0x00000000	0xffffffff	—	—
0x63	R/W	AuthenKey3	Hex	4	0x00000000	0xffffffff	—	—
0x64	R/W	AuthenKey2	Hex	4	0x00000000	0xffffffff	—	—
0x65	R/W	AuthenKey1	Hex	4	0x00000000	0xffffffff	—	—
0x66	R/W	AuthenKey0	Hex	4	0x00000000	0xffffffff	—	—
0x68	R	SafetyAlert2	Hex	2	0x0000	0x000f	—	—
0x69	R	SafetyStatus2	Hex	2	0x0000	0x000f	—	—
0x6a	R	PFAAlert2	Hex	2	0x0000	0x000f	—	—
0x6b	R	PFStatus2	Hex	2	0x0000	0x000f	—	—
0x6c	R/W	ManufBlock1	String	20	—	—	—	—
0x6d	R/W	ManufBlock2	String	20	—	—	—	—
0x6e	R/W	ManufBlock3	String	20	—	—	—	—
0x6f	R/W	ManufBlock4	String	20	—	—	—	—
0x70	R/W	ManufacturerInfo	String	31+1	—	—	—	—
0x71	R/W	SenseResistor	Unsigned Integer	2	0	65,535	—	μΩ
0x72	R	TempRange	Hex	2	0x0000	0xffff	—	—
0x73	R	LifetimeData1	String	32+1	—	—	—	—
0x74	R	LifetimeData2	String	8+1	—	—	—	—
0x77	R/W	DataFlashSubClassID	Hex	2	0x0000	0xffff	—	—
0x78	R/W	DataFlashSubClassPage1	Hex	32	—	—	—	—
0x79	R/W	DataFlashSubClassPage2	Hex	32	—	—	—	—
0x7a	R/W	DataFlashSubClassPage3	Hex	32	—	—	—	—
0x7b	R/W	DataFlashSubClassPage4	Hex	32	—	—	—	—
0x7c	R/W	DataFlashSubClassPage5	Hex	32	—	—	—	—
0x7d	R/W	DataFlashSubClassPage6	Hex	32	—	—	—	—
0x7e	R/W	DataFlashSubClassPage7	Hex	32	—	—	—	—
0x7f	R/W	DataFlashSubClassPage8	Hex	32	—	—	—	—

APPLICATION SCHEMATIC

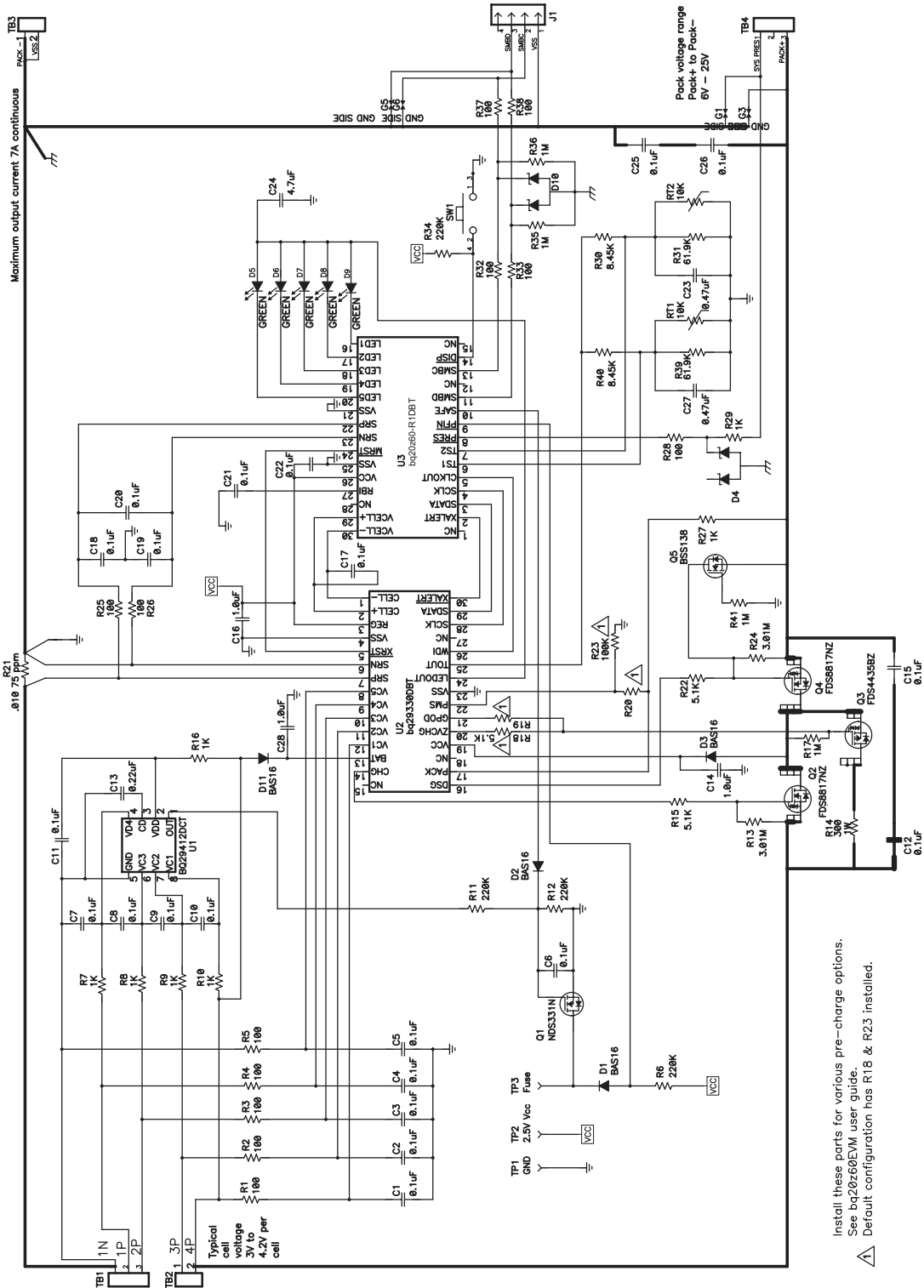

Install these parts for various pre-charge options.  
See bq20z60EVM user guide.  
Default configuration has R1

---

**REVISION HISTORY**

<b>Changes from Original (December 2009) to Revision A</b>	<b>Page</b>
• Added the 32-pin QFN (RSM) package .....	<a href="#">1</a>

---

**PACKAGING INFORMATION**

Orderable Device	Status (1)	Package Type	Package Drawing	Pins	Package Qty	Eco Plan (2)	Lead/Ball Finish (6)	MSL Peak Temp (3)	Op Temp (°C)	Device Marking (4/5)	Samples
BQ20Z60DBT-R1	NRND	TSSOP	DBT	30	60	Green (RoHS & no Sb/Br)	CU NIPDAU	Level-2-260C-1 YEAR	-40 to 85	20Z60	
BQ20Z60DBTR-R1	NRND	TSSOP	DBT	30	2000	Green (RoHS & no Sb/Br)	CU NIPDAU	Level-2-260C-1 YEAR	-40 to 85	20Z60	

(1) The marketing status values are defined as follows:

**ACTIVE:** Product device recommended for new designs.

**LIFEBUY:** TI has announced that the device will be discontinued, and a lifetime-buy period is in effect.

**NRND:** Not recommended for new designs. Device is in production to support existing customers, but TI does not recommend using this part in a new design.

**PREVIEW:** Device has been announced but is not in production. Samples may or may not be available.

**OBsolete:** TI has discontinued the production of the device.

(2) Eco Plan - The planned eco-friendly classification: Pb-Free (RoHS), Pb-Free (RoHS Exempt), or Green (RoHS & no Sb/Br) - please check <http://www.ti.com/productcontent> for the latest availability information and additional product content details.

**TBD:** The Pb-Free/Green conversion plan has not been defined.

**Pb-Free (RoHS):** TI's terms "Lead-Free" or "Pb-Free" mean semiconductor products that are compatible with the current RoHS requirements for all 6 substances, including the requirement that lead not exceed 0.1% by weight in homogeneous materials. Where designed to be soldered at high temperatures, TI Pb-Free products are suitable for use in specified lead-free processes.

**Pb-Free (RoHS Exempt):** This component has a RoHS exemption for either 1) lead-based flip-chip solder bumps used between the die and package, or 2) lead-based die adhesive used between the die and leadframe. The component is otherwise considered Pb-Free (RoHS compatible) as defined above.

**Green (RoHS & no Sb/Br):** TI defines "Green" to mean Pb-Free (RoHS compatible), and free of Bromine (Br) and Antimony (Sb) based flame retardants (Br or Sb do not exceed 0.1% by weight in homogeneous material)

(3) MSL, Peak Temp. - The Moisture Sensitivity Level rating according to the JEDEC industry standard classifications, and peak solder temperature.

(4) There may be additional marking, which relates to the logo, the lot trace code information, or the environmental category on the device.

(5) Multiple Device Markings will be inside parentheses. Only one Device Marking contained in parentheses and separated by a "~" will appear on a device. If a line is indented then it is a continuation of the previous line and the two combined represent the entire Device Marking for that device.

(6) Lead/Ball Finish - Orderable Devices may have multiple material finish options. Finish options are separated by a vertical ruled line. Lead/Ball Finish values may wrap to two lines if the finish value exceeds the maximum column width.

**Important Information and Disclaimer:** The information provided on this page represents TI's knowledge and belief as of the date that it is provided. TI bases its knowledge and belief on information provided by third parties, and makes no representation or warranty as to the accuracy of such information. Efforts are underway to better integrate information from third parties. TI has taken and continues to take reasonable steps to provide representative and accurate information but may not have conducted destructive testing or chemical analysis on incoming materials and chemicals. TI and TI suppliers consider certain information to be proprietary, and thus CAS numbers and other limited information may not be available for release.

In no event shall TI's liability arising out of such information exceed the total purchase price of the TI part(s) at issue in this document sold by TI to Customer on an annual basis.

**TAPE AND REEL INFORMATION**
**REEL DIMENSIONS**

**TAPE DIMENSIONS**

A0	Dimension designed to accommodate the component width
B0	Dimension designed to accommodate the component length
K0	Dimension designed to accommodate the component thickness
W	Overall width of the carrier tape
P1	Pitch between successive cavity centers

**TAPE AND REEL INFORMATION**

\*All dimensions are nominal

Device	Package Type	Package Drawing	Pins	SPQ	Reel Diameter (mm)	Reel Width W1 (mm)	A0 (mm)	B0 (mm)	K0 (mm)	P1 (mm)	W (mm)	Pin1 Quadrant
BQ20Z60DBTR-R1	TSSOP	DBT	30	2000	330.0	16.4	6.95	8.3	1.6	8.0	16.0	Q1

**TAPE AND REEL BOX DIMENSIONS**



\*All dimensions are nominal

Device	Package Type	Package Drawing	Pins	SPQ	Length (mm)	Width (mm)	Height (mm)
BQ20Z60DBTR-R1	TSSOP	DBT	30	2000	367.0	367.0	38.0

DBT (R-PDSO-G30)

PLASTIC SMALL OUTLINE

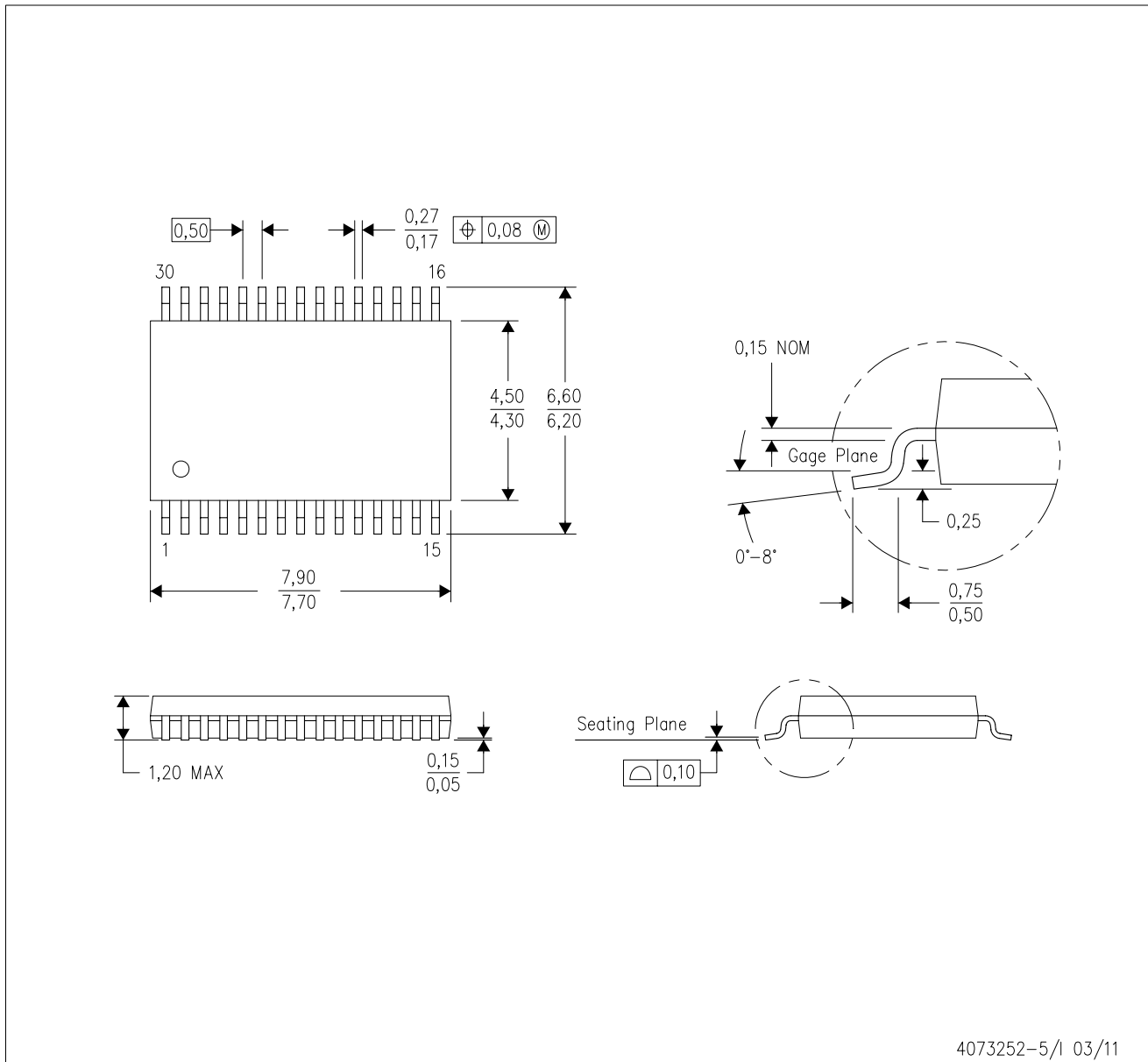

- NOTES:
- A. All linear dimensions are in millimeters. Dimensioning and tolerancing per ASME Y14.5M-1994.
  - B. This drawing is subject to change without notice.
  - C. Body dimensions do not include mold flash or protrusion.
  - D. Falls within JEDEC MO-153.

## IMPORTANT NOTICE

Texas Instruments Incorporated and its subsidiaries (TI) reserve the right to make corrections, enhancements, improvements and other changes to its semiconductor products and services per JESD46, latest issue, and to discontinue any product or service per JESD48, latest issue. Buyers should obtain the latest relevant information before placing orders and should verify that such information is current and complete. All semiconductor products (also referred to herein as "components") are sold subject to TI's terms and conditions of sale supplied at the time of order acknowledgment.

TI warrants performance of its components to the specifications applicable at the time of sale, in accordance with the warranty in TI's terms and conditions of sale of semiconductor products. Testing and other quality control techniques are used to the extent TI deems necessary to support this warranty. Except where mandated by applicable law, testing of all parameters of each component is not necessarily performed.

TI assumes no liability for applications assistance or the design of Buyers' products. Buyers are responsible for their products and applications using TI components. To minimize the risks associated with Buyers' products and applications, Buyers should provide adequate design and operating safeguards.

TI does not warrant or represent that any license, either express or implied, is granted under any patent right, copyright, mask work right, or other intellectual property right relating to any combination, machine, or process in which TI components or services are used. Information published by TI regarding third-party products or services does not constitute a license to use such products or services or a warranty or endorsement thereof. Use of such information may require a license from a third party under the patents or other intellectual property of the third party, or a license from TI under the patents or other intellectual property of TI.

Reproduction of significant portions of TI information in TI data books or data sheets is permissible only if reproduction is without alteration and is accompanied by all associated warranties, conditions, limitations, and notices. TI is not responsible or liable for such altered documentation. Information of third parties may be subject to additional restrictions.

Resale of TI components or services with statements different from or beyond the parameters stated by TI for that component or service voids all express and any implied warranties for the associated TI component or service and is an unfair and deceptive business practice. TI is not responsible or liable for any such statements.

Buyer acknowledges and agrees that it is solely responsible for compliance with all legal, regulatory and safety-related requirements concerning its products, and any use of TI components in its applications, notwithstanding any applications-related information or support that may be provided by TI. Buyer represents and agrees that it has all the necessary expertise to create and implement safeguards which anticipate dangerous consequences of failures, monitor failures and their consequences, lessen the likelihood of failures that might cause harm and take appropriate remedial actions. Buyer will fully indemnify TI and its representatives against any damages arising out of the use of any TI components in safety-critical applications.

In some cases, TI components may be promoted specifically to facilitate safety-related applications. With such components, TI's goal is to help enable customers to design and create their own end-product solutions that meet applicable functional safety standards and requirements. Nonetheless, such components are subject to these terms.

No TI components are authorized for use in FDA Class III (or similar life-critical medical equipment) unless authorized officers of the parties have executed a special agreement specifically governing such use.

Only those TI components which TI has specifically designated as military grade or "enhanced plastic" are designed and intended for use in military/aerospace applications or environments. Buyer acknowledges and agrees that any military or aerospace use of TI components which have **not** been so designated is solely at the Buyer's risk, and that Buyer is solely responsible for compliance with all legal and regulatory requirements in connection with such use.

TI has specifically designated certain components as meeting ISO/TS16949 requirements, mainly for automotive use. In any case of use of non-designated products, TI will not be responsible for any failure to meet ISO/TS16949.

### Products

Audio	<a href="http://www.ti.com/audio">www.ti.com/audio</a>
Amplifiers	<a href="http://amplifier.ti.com">amplifier.ti.com</a>
Data Converters	<a href="http://dataconverter.ti.com">dataconverter.ti.com</a>
DLP® Products	<a href="http://www.dlp.com">www.dlp.com</a>
DSP	<a href="http://dsp.ti.com">dsp.ti.com</a>
Clocks and Timers	<a href="http://www.ti.com/clocks">www.ti.com/clocks</a>
Interface	<a href="http://interface.ti.com">interface.ti.com</a>
Logic	<a href="http://logic.ti.com">logic.ti.com</a>
Power Mgmt	<a href="http://power.ti.com">power.ti.com</a>
Microcontrollers	<a href="http://microcontroller.ti.com">microcontroller.ti.com</a>
RFID	<a href="http://www.ti-rfid.com">www.ti-rfid.com</a>
OMAP Applications Processors	<a href="http://www.ti.com/omap">www.ti.com/omap</a>
Wireless Connectivity	<a href="http://www.ti.com/wirelessconnectivity">www.ti.com/wirelessconnectivity</a>

### Applications

Automotive and Transportation	<a href="http://www.ti.com/automotive">www.ti.com/automotive</a>
Communications and Telecom	<a href="http://www.ti.com/communications">www.ti.com/communications</a>
Computers and Peripherals	<a href="http://www.ti.com/computers">www.ti.com/computers</a>
Consumer Electronics	<a href="http://www.ti.com/consumer-apps">www.ti.com/consumer-apps</a>
Energy and Lighting	<a href="http://www.ti.com/energy">www.ti.com/energy</a>
Industrial	<a href="http://www.ti.com/industrial">www.ti.com/industrial</a>
Medical	<a href="http://www.ti.com/medical">www.ti.com/medical</a>
Security	<a href="http://www.ti.com/security">www.ti.com/security</a>
Space, Avionics and Defense	<a href="http://www.ti.com/space-avionics-defense">www.ti.com/space-avionics-defense</a>
Video and Imaging	<a href="http://www.ti.com/video">www.ti.com/video</a>

### TI E2E Community

[e2e.ti.com](http://e2e.ti.com)